

CURTAIN WALL SYSTEM

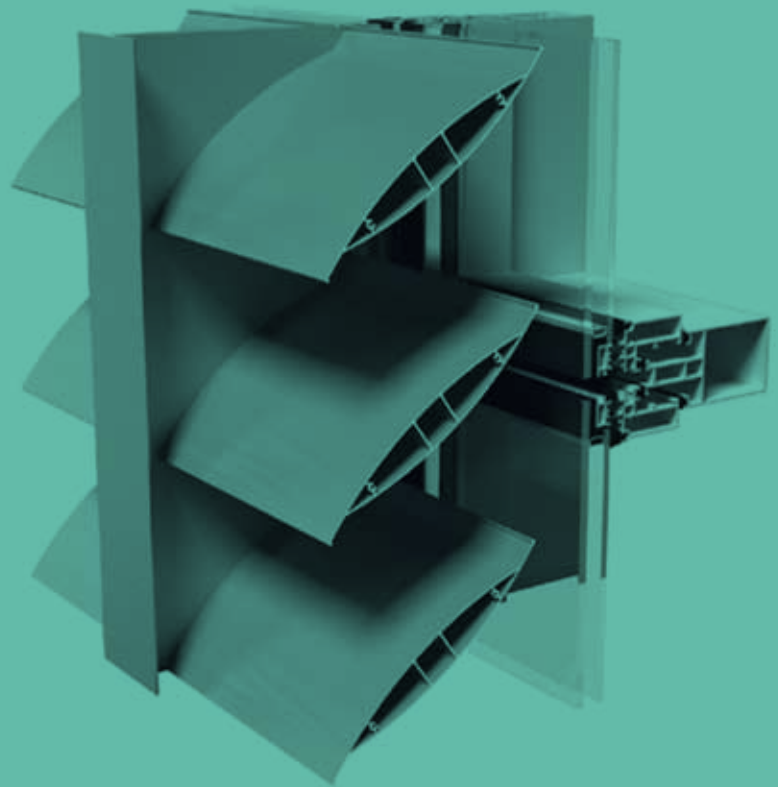

СИСТЕМА ЗА ОКАЧЕНА ФАСАДА



- 60 mm system width
- A specific feature is the cassette structure built on a traditional stick system
 - The system allows top hung or parrallel opening vents with the same outer appearance as the fixed cassettes
 - Variations of the system
 - classical – four side aluminium cap semi-structural facade with 15 mm framing profile
 - structural facade
 - The connection between the cassettes and the main structure is implemented by positioning locks, allowing dynamic load absorption
- Possibility to use various types of materials in the cassettes - glazings, etalbond®, fibre-cement plates, HPL
 - Use of photovoltaic panels
- Special accessories - consoles for mounting of sun protection in front of the curtain wall
 - Possibility to execute complex space constructions and roofs
 - Opening parts
 - Top-hung vents
 - Parallel opening vents
- Compatibility with all window systems of ETEM for the pressure plate type
 - Ширина на системата 60 мм
 - Специфична особеност за системата е наличието на “крила” по периметъра на модулите
- Системата позволява всяка неотваряема част да се превърне в отваряема, без визуална разлика по фасадата
 - Съществува в различни вариации
- Връзката между “крилата” и основната конструкция се осъществява с фиксатори, позволяващи поемане на динамични натоварвания
 - Възможност за влагане на различни видове материали в бръстунговите зони стъклопакети, etalbond®, етернит, текстолит
 - Влагане на фотоволтаични панели
- Специални аксесоари – конзоли за монтаж на жалузи пред окачена фасада
 - Възможност за изпълнение на сложни пространствени конструкции и покриви
 - Отваряеми части
 - тип клапа с отваряне в долната част на модула
 - клапа с ножици за паралелно отваряне
 - съвместимост с всички отваряеми системи ETEM за варианта с капачка





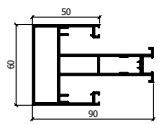
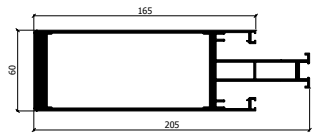
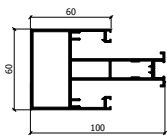
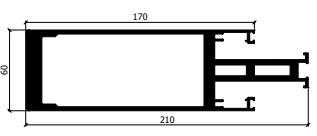
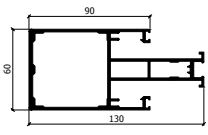
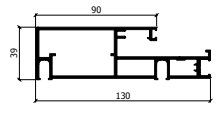
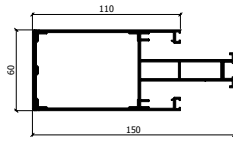
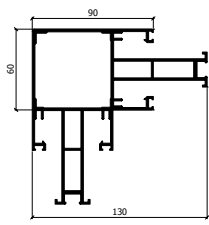
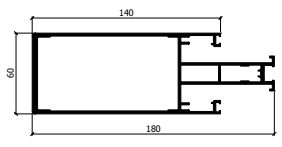
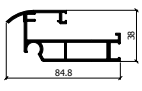
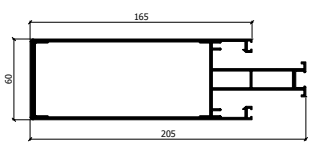
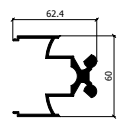



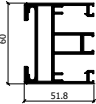
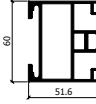
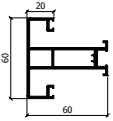
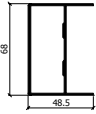
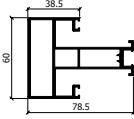
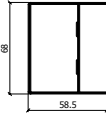
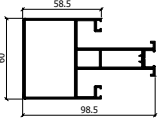
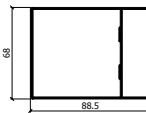
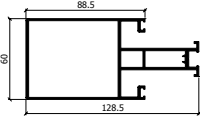
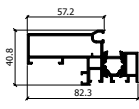
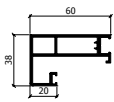
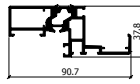

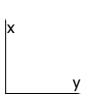
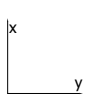
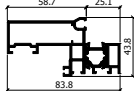
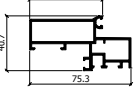

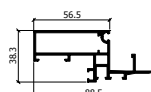
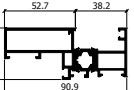
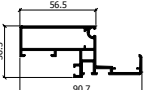
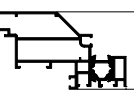
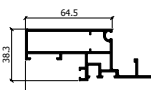

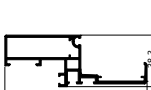
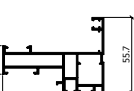



certificates сертификати



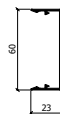
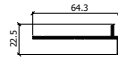



- **Certificates for thermal transmittance, issued by ift Rosenheim:**
 - $U_{cw}=1,9 \text{ W}/(\text{m}^2.\text{K})$ – for sample with 28 mm glazing with krypton
 - $U_f = 3,8-4,7 \text{ W}/(\text{m}^2.\text{K})$ – for various combinations
- **Certificate for air permeability, watertightness, resistance to wind load, impact resistance and hose test, issued by ift Rosenheim:**
 - air permeability – class AE
 - watertightness – class RE 1500
 - resistance to wind load – design load $\pm 1,6 \text{ kN}/\text{m}^2$; safety load $\pm 2,4 \text{ kN}/\text{m}^2$
 - impact resistance - I5/E5
 - hose test – no water penetration
- **Сертификати за топлопреминаване, издадени от ift Rosenheim:**
 - $U_{cw} = 1,9 \text{ W}/(\text{m}^2.\text{K})$ – за мостра със стъклопакет 28 мм с криптон
 - $U_f = 3,8-4,7 \text{ W}/(\text{m}^2.\text{K})$ – за различните видове комбинации
- **Сертификат за въздухопропускливост, водонепропускливост, устойчивост на вятър, удароустойчивост и изпитване с водна струя , издаден от ift Rosenheim:**
 - въздухопропускливост – клас AE
 - водонепропускливост – клас RE 1500
 - устойчивост на вятър – допустимо натоварване $\pm 1,6 \text{ kN}/\text{m}^2$; пределно натоварване $\pm 2,4 \text{ kN}/\text{m}^2$
 - удароустойчивост – I5/E5
 - изпитване с водна струя – без проникване на вода

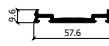
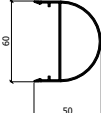





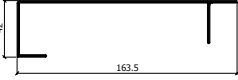
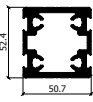
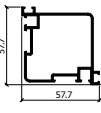
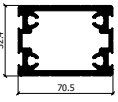
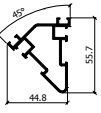
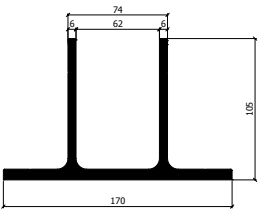

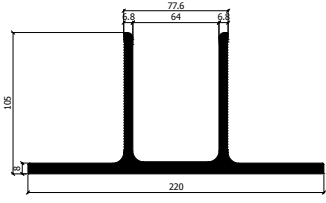
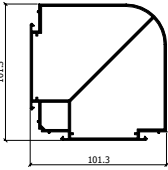



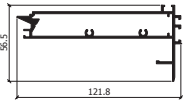

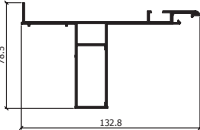
CODE	 profile профил	weight length moment of inertia	CODE	 profile профил	weight length moment of inertia
E 8100		2141 g/m L=6.6 m $I_x=56.2 \text{ cm}^4$ $I_y=26.36 \text{ cm}^4$	E 8107		5290 g/m L=6.6 m $I_x=901.11 \text{ cm}^4$ $I_y=87.28 \text{ cm}^4$
E 8101		2352 g/m L=6.6 m $I_x=74.57 \text{ cm}^4$ $I_y=31.26 \text{ cm}^4$	E 8105		7557 g/m L=6.6 m $I_x=1329.33 \text{ cm}^4$ $I_y=113.48 \text{ cm}^4$
E 8102		2978 g/m L=6.6 m $I_x=173.66 \text{ cm}^4$ $I_y=46.27 \text{ cm}^4$	E 8152		2344 g/m L=6.6 m $I_x=138.29 \text{ cm}^4$ $I_y=16.1 \text{ cm}^4$
E 8103		3173 g/m L=6.6 m $I_x=254.03 \text{ cm}^4$ $I_y=53.08 \text{ cm}^4$	E 8142		4139 g/m L=6.6 m $I_x=196.5 \text{ cm}^4$ $I_y=196.5 \text{ cm}^4$
E 8104		3702 g/m L=6.6 m $I_x=454.03 \text{ cm}^4$ $I_y=66.32 \text{ cm}^4$	E 8652		1388 g/m L=6.6 m $I_x=28.85 \text{ cm}^4$ $I_y=8.03 \text{ cm}^4$
E 8106		3961 g/m L=6.6 m $I_x=639.1 \text{ cm}^4$ $I_y=75.48 \text{ cm}^4$	E 8653		1498 g/m L=6.6 m $I_x=15.19 \text{ cm}^4$ $I_y=16.61 \text{ cm}^4$

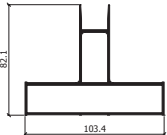

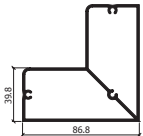
CODE	 profile профил	weight length moment of inertia	CODE	 profile профил	weight length moment of inertia
E 8170		2141 g/m L=6.6 m $I_x=17.77 \text{ cm}^4$ $I_y=32.28 \text{ cm}^4$	E 8370		1766 g/m L=6.01 m $I_x=18.32 \text{ cm}^4$ $I_y=30.25 \text{ cm}^4$
E 8300		2352 g/m L=6.6 m $I_x=20.4 \text{ cm}^4$ $I_y=12.59 \text{ cm}^4$	E 8602		1064 g/m L=6.01 m $I_x=8.19 \text{ cm}^4$ $I_y=24.44 \text{ cm}^4$
E 8304		2978 g/m L=6.6 m $I_x=36.97 \text{ cm}^4$ $I_y=20.28 \text{ cm}^4$	E 8604		1145 g/m L=6.01 m $I_x=14.39 \text{ cm}^4$ $I_y=27.76 \text{ cm}^4$
E 8301		3173 g/m L=6.6 m $I_x=65.03 \text{ cm}^4$ $I_y=25.63 \text{ cm}^4$	E 8619		1388 g/m L=6.01 m $I_x=46.28 \text{ cm}^4$ $I_y=37.71 \text{ cm}^4$
E 8302		3702 g/m L=6.6 m $I_x=129.76 \text{ cm}^4$ $I_y=33.33 \text{ cm}^4$	E 8250		1485 g/m L=6.01 m $I_x=29.59 \text{ cm}^4$ $I_y=6.35 \text{ cm}^4$
E 8303		3961 g/m L=6.6 m $I_x=16.09 \text{ cm}^4$ $I_y=5.55 \text{ cm}^4$	E 8260		1457 g/m L=6.01 m $I_x=28.41 \text{ cm}^4$ $I_y=6.99 \text{ cm}^4$

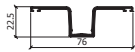
CODE		profile профил	weight length moment of inertia	CODE		profile профил	weight length moment of inertia
E 8270 parallel opening		1572 g/m L=6.01 m $I_x=32.37 \text{ cm}^4$ $I_y=7.94 \text{ cm}^4$	E 8203		1191 g/m L=6.01 m $I_x=21.52 \text{ cm}^4$ $I_y=5.83 \text{ cm}^4$		
E 8251		1678 g/m L=6.01 m $I_x=39.57 \text{ cm}^4$ $I_y=9.71 \text{ cm}^4$	E 8201		1233 g/m L=6.01 m $I_x=24.25 \text{ cm}^4$ $I_y=6.44 \text{ cm}^4$		
E 8252		1598 g/m L=6.01 m $I_x=39.99 \text{ cm}^4$ $I_y=6.34 \text{ cm}^4$	E 8200		1253 g/m L=6.01 m $I_x=28.03 \text{ cm}^4$ $I_y=7.15 \text{ cm}^4$		
E 8255		2057 g/m L=6.01 m $I_x=68.72 \text{ cm}^4$ $I_y=20.35 \text{ cm}^4$	E 8202		1327 g/m L=6.01 m $I_x=30.45 \text{ cm}^4$ $I_y=7.73 \text{ cm}^4$		
E 8452		1376 g/m L=6.01 m $I_x=33.82 \text{ cm}^4$ $I_y=10.24 \text{ cm}^4$	E 8205		1402 g/m L=6.01 m $I_x=43.19 \text{ cm}^4$ $I_y=8.3 \text{ cm}^4$		
E 8204		1381 g/m L=6.01 m $I_x=29.65 \text{ cm}^4$ $I_y=9.32 \text{ cm}^4$	E 2309		197 g/m L=4.40 m		

CODE		profile профил	weight length moment of inertia	CODE		profile профил	weight length moment of inertia
E 8603			190 g/m L=6.01 m	E 6406			423 g/m L=6.01 m
E 8608			125 g/m L=6.01 m	E 8701			460.2 g/m L=6.01 m
E 8610			431 g/m L=6.01 m	E 8700			479.2 g/m L=6.01 m
E 8611			130 g/m L=6.01 m	E 6409			392 g/m L=6.01 m
E 8908			425 g/m L=6.01 m	E 6439			410 g/m L=6.01 m
E 8620			554 g/m L=6.01 m	E 6443			795 g/m L=6.01 m

CODE	 profile профил	weight length moment of inertia	CODE	 profile профил	weight length moment of inertia
E 6442		1140 g/m L=6.01 m $I_x=30.3 \text{ cm}^4$ $I_y=26 \text{ cm}^4$	E 8960		4102 g/m L=6.01 m $I_x=389.55 \text{ cm}^4$ $I_y=1.13 \text{ cm}^4$
E 6446		575 g/m L=6.01 m	E 8656		1233 g/m L=6.01 m $I_x=144.82 \text{ cm}^4$ $I_y=8.56 \text{ cm}^4$
E 8950		2749 g/m L=6.01 m $I_x=32.16 \text{ cm}^4$ $I_y=35.95 \text{ cm}^4$	E 8650		1083 g/m L=6.01 m $I_x=15.94 \text{ cm}^4$ $I_y=15.94 \text{ cm}^4$
E 8951		3175 g/m L=6.01 m $I_x=76.14 \text{ cm}^4$ $I_y=45.25 \text{ cm}^4$	E 8651		877 g/m L=6.01 m $I_x=5.48 \text{ cm}^4$ $I_y=7.53 \text{ cm}^4$
E 6414		6957 g/m L=6.01 m $I_x=468.24 \text{ cm}^4$ $I_y=266.02 \text{ cm}^4$	E 8670		1256 g/m L=6.01 m $I_x=39.71 \text{ cm}^4$ $I_y=2.76 \text{ cm}^4$
E 8914		8429 g/m L=6.01 m $I_x=873.38 \text{ cm}^4$ $I_y=298.09 \text{ cm}^4$	E 8802		2696 g/m L=6.01 m $I_x=126.54 \text{ cm}^4$ $I_y=126.54 \text{ cm}^4$

CODE	 profile профил	weight length moment of inertia	CODE	 profile профил	weight length moment of inertia
E 8659		1588 g/m L=6.01 m $I_x=96.5 \text{ cm}^4$ $I_y=8.37 \text{ cm}^4$	E 8853		588 g/m L=6.01 m
E 8800		1605 g/m L=6.01 m $I_x=67.31 \text{ cm}^4$ $I_y=29.87 \text{ cm}^4$	E 8660		448 g/m L=6.01 m
E 8801		1721 g/m L=6.01 m $I_x=50.78 \text{ cm}^4$ $I_y=32.59 \text{ cm}^4$	E 8850		203 g/m L=6.01 m
E 8658		2004 g/m L=6.01 m $I_x=62.6 \text{ cm}^4$ $I_y=62.67 \text{ cm}^4$	E 8852		111 g/m L=6.01 m
E 8851		635 g/m L=6.01 m	E 8863		235 g/m L=6.01 m
E 8601		783 g/m L=6.01 m $I_x=4.83 \text{ cm}^4$ $I_y=0.71 \text{ cm}^4$	E 33410		641 g/m L=6.01 m

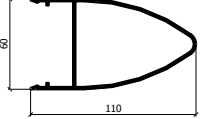
CODE	 profile профил	weight length moment of inertia	CODE	 profile профил	weight length moment of inertia
E 14575		1218 g/m L=6.01 m			

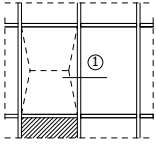

①

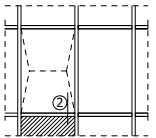
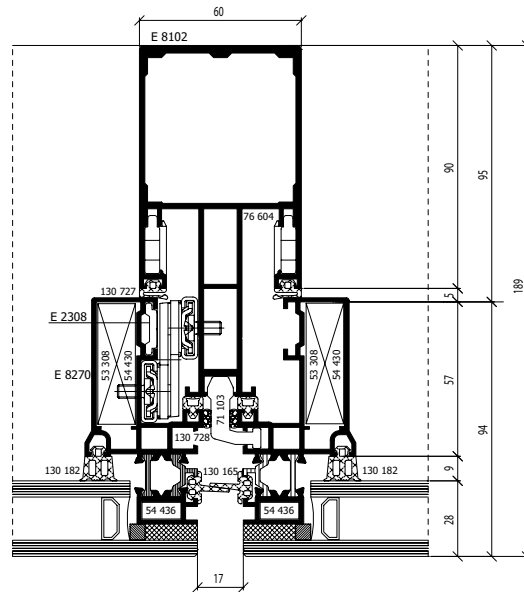

②

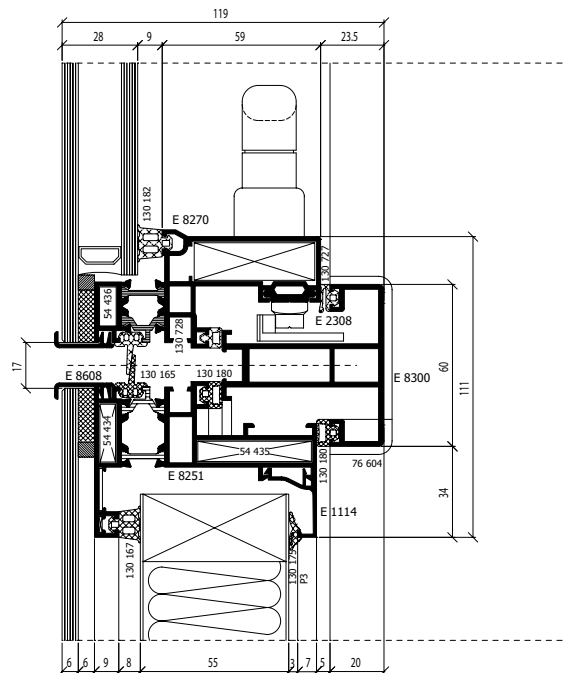

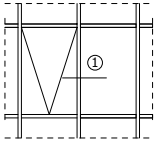

①

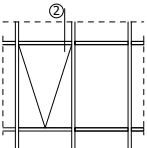
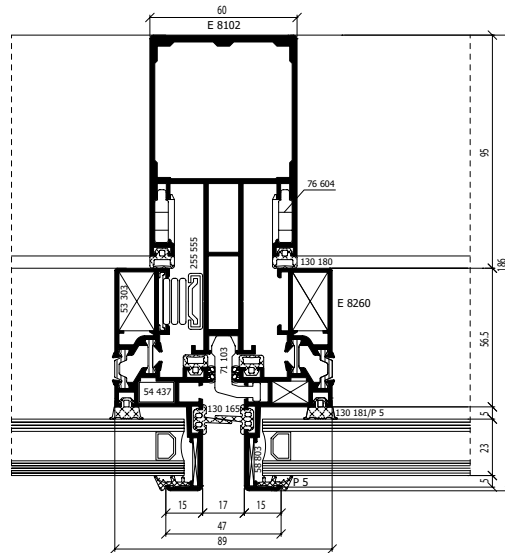

②

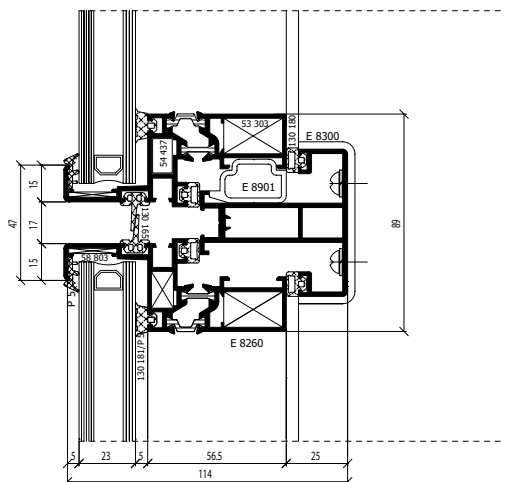

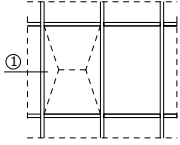

1

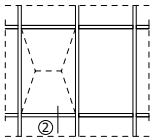
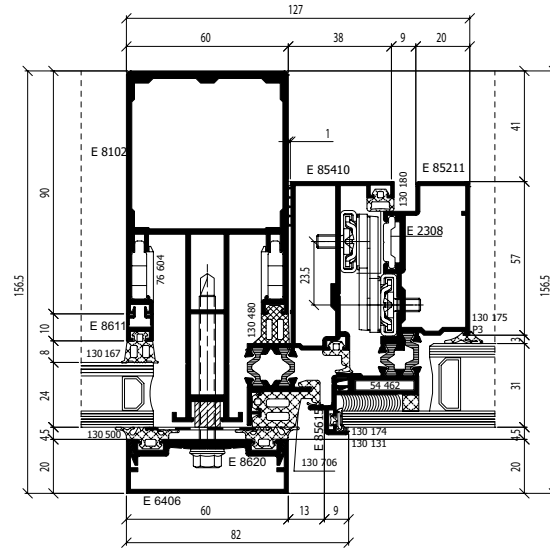

2

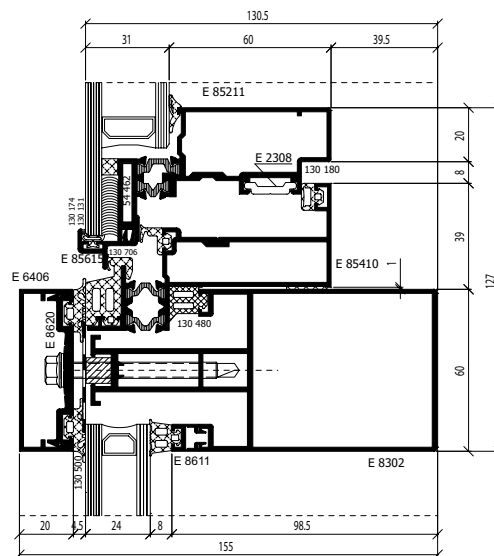

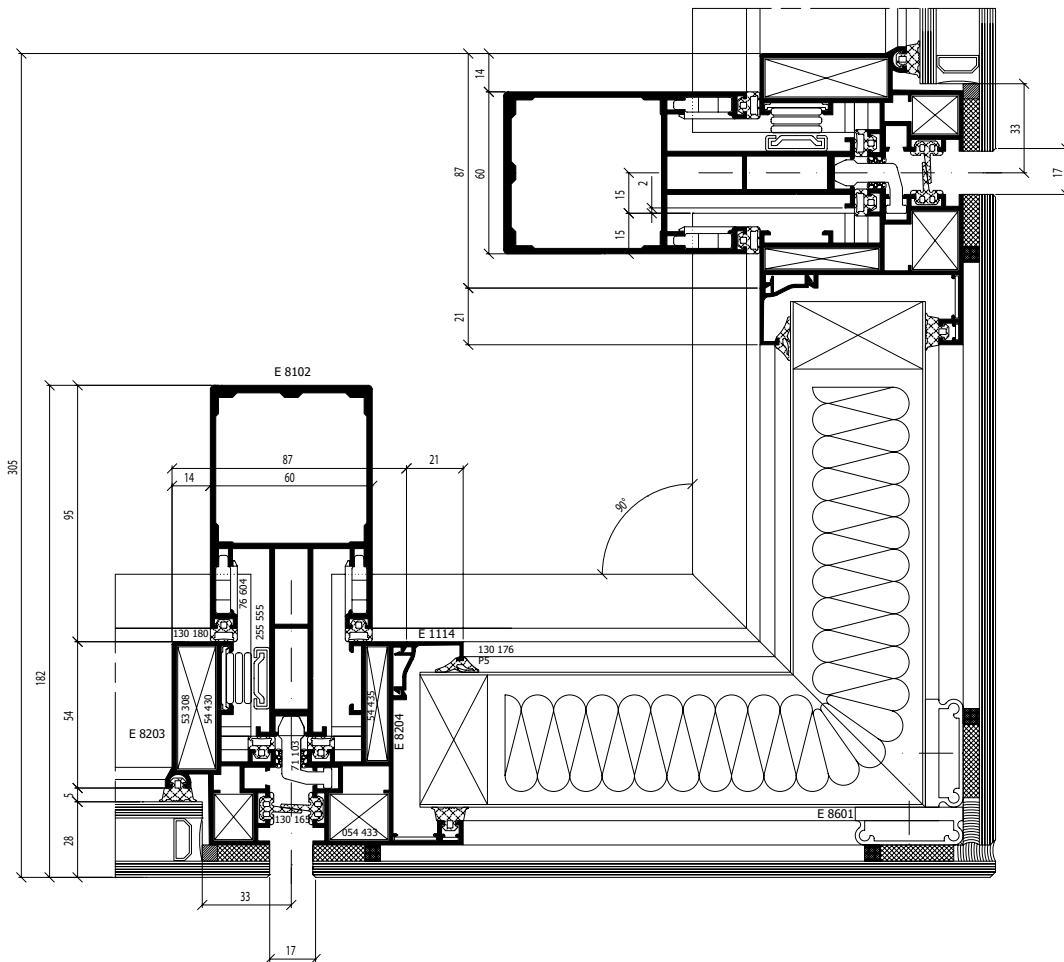
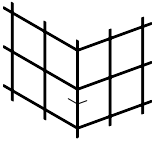

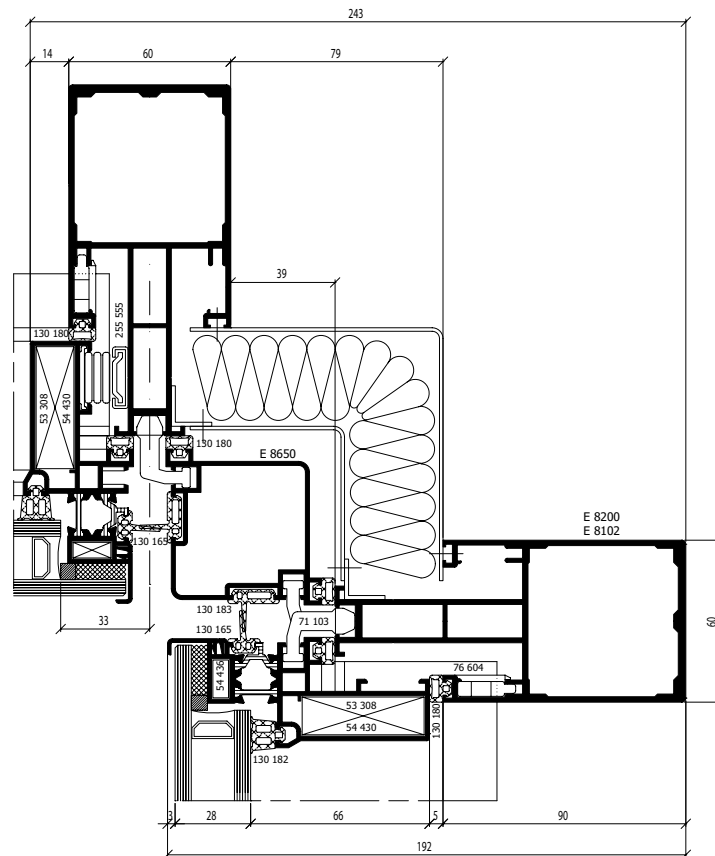
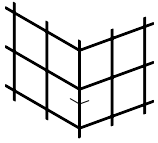

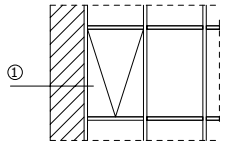

①

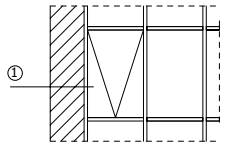
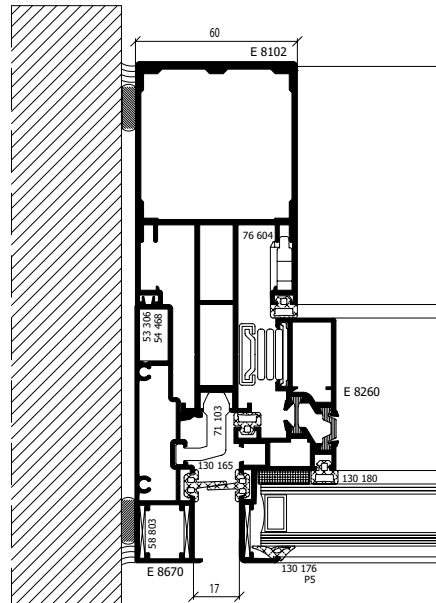

①

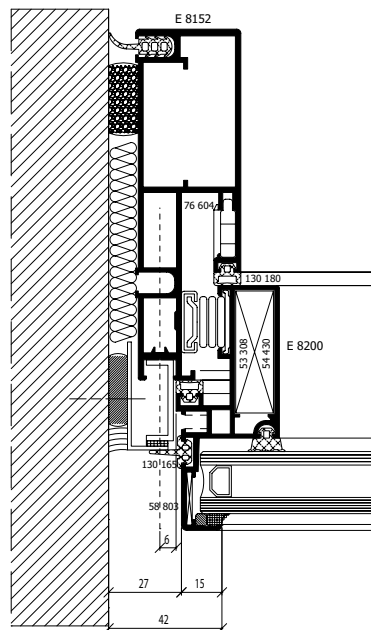

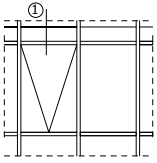

1

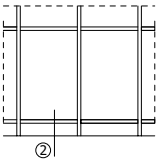
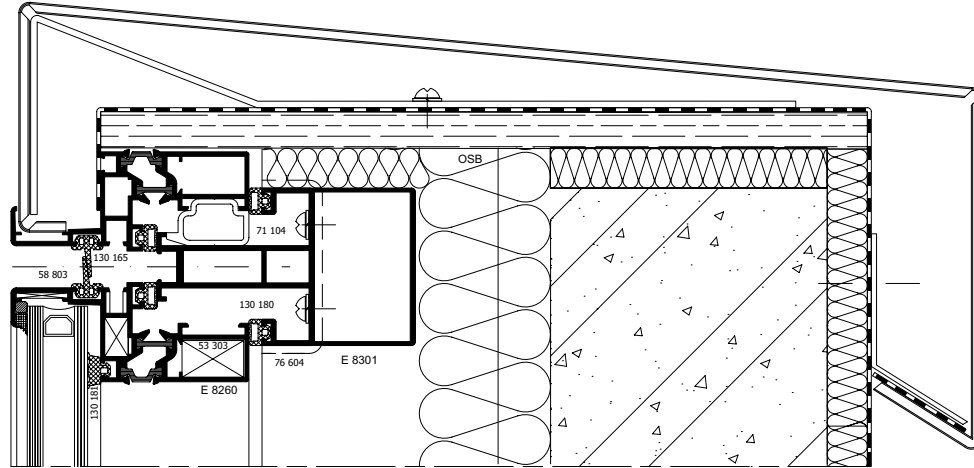

2

